

THESE CONFIDENTIAL DOCUMENTS SUBMITTED BY JANUS CONTAIN INFORMATION OF A PROPRIETARY NATURE AND MAY NOT BE REPRODUCED OR USED TO MANUFACTURE ANYTHING IN PART OR IN WHOLE FOR ANY PURPOSE OTHER THAN THAT WHICH IS NECESSARY FOR PREPARATION OF BIDS OF ENGINEERING WITHOUT THE EXPRESS PERMISSION OF JANUS WHICH MAY RECALL DOCUMENTS AT ANY TIME.

UNLESS OTHERWISE SPECIFIED DIMENSIONS ARE IN INCHES AND TOLERANCES ARE:

DECIMAL	FRACTIONS	ANGLES	HOLE DIAMETERS
.XX ±.03	1/16 ±.005	±.004	UNDER .251 +.004 -.003
.XXX ±.005	1/32 ±.001	±.003	.251 to .500 +.006 -.003
			OVER .500 +.008 -.003

PART NUMBER: \_\_\_\_\_  
 MATERIAL: \_\_\_\_\_  
 APPLIED FINISH: \_\_\_\_\_  
 UNIT OF MEASURE: \_\_\_\_\_  
 APPROVALS: \_\_\_\_\_ DATE: \_\_\_\_\_  
 DRAWN: BECKY NELSON 5-30-07  
 CHECKED: DON MILLS 5-30-07  
 APPROVED: DON MILLS 5-30-07

**JANUS INTERNATIONAL CORPORATION**  
 134 EAST LUKE ROAD TEMPLE, GA 30179-4435  
 770-562-2850/Fax 770-562-2264  
 © 2007 Janus International Corporation All Rights Reserved

**CERTIFIED WIND LOAD RATED**  
 26 GA SERIES 1100 DOOR ASSEMBLY  
 MAX. SIZE 8'-8" X 14'-0"

SIZE: \_\_\_\_\_ DRAWING NUMBER: **T1012** REV: **A**  
 SCALE: NONE SHEET: 1 OF 2

STATE OF TEXAS  
 JOSEPH H. DIXON, JR.  
 18627  
 LICENSED PROFESSIONAL ENGINEER  
 10/2/10

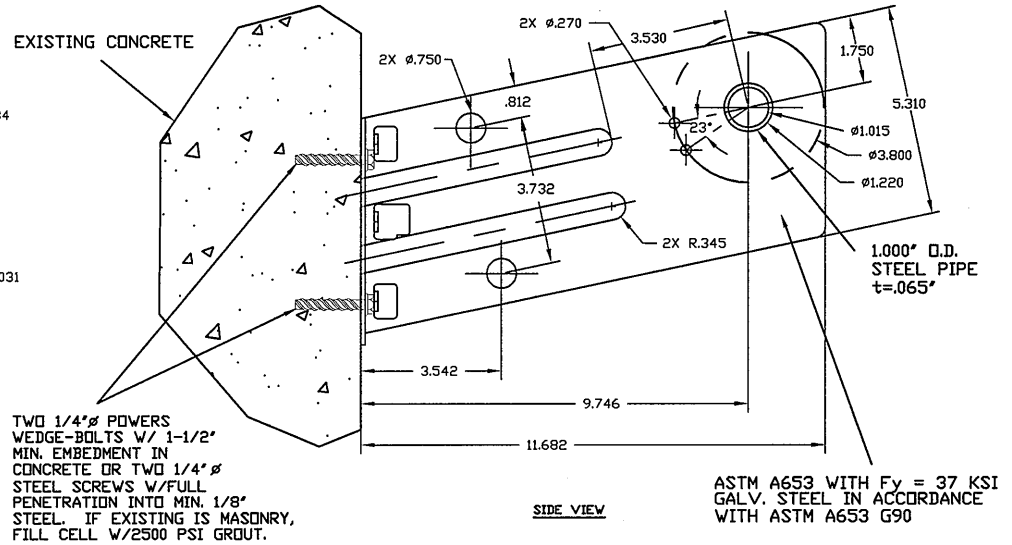
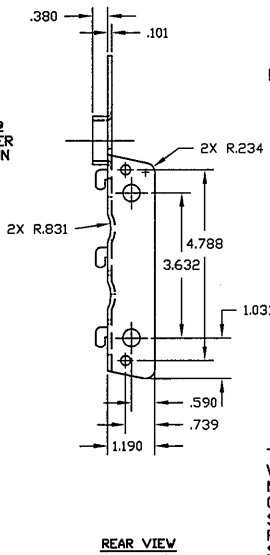
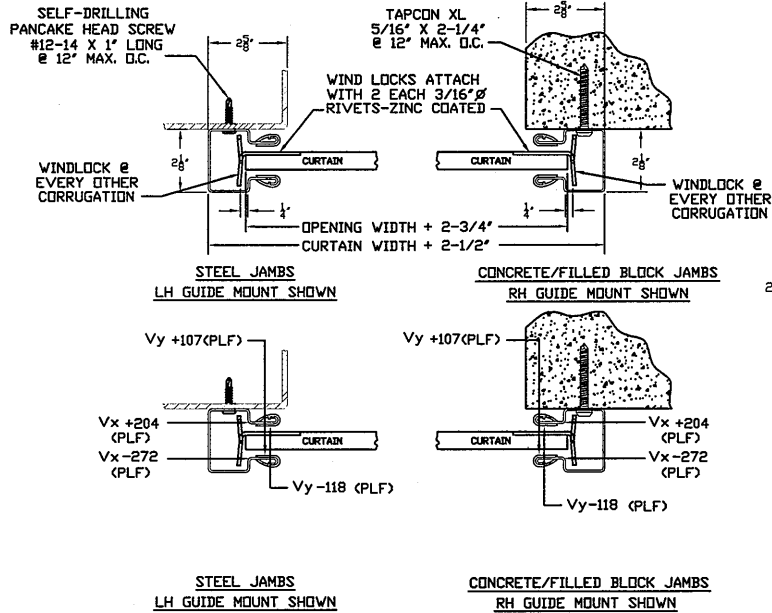

REVISIONS			
REV	DESCRIPTION	DATE	APPROVAL
—	DRAWING RELEASE	5-30-07	DM
A	NOTE REVISIONS	6-17-09	CS

SUPERIMPOSED LOAD DIAGRAM

DOOR MOUNTING BRACKET DETAIL

GENERAL NOTES

- THIS ROLL-UP DOOR SYSTEM IS DESIGNED IN ACCORDANCE WITH THE FLORIDA BUILDING CODE.
- THIS ROLL-UP DOOR HAS BEEN TESTED IN ACCORDANCE WITH ASTM E-330 AND COMPLIES WITH ANSI/DASMA 108.

DESIGN LOAD = +24.4 psf  
-27.0

- WIND LOADS FOR BUILDING OPENINGS SHALL BE DETERMINED BY A PROFESSIONAL ENGINEER USING APPROPRIATE WIND SPEED AND DESIGN CRITERIA. THIS DOOR MAY BE USED WHERE THE DESIGN LOAD MEETS OR EXCEEDS THE DESIGN LOAD FOR THE BUILDING OPENING.
- SUPERIMPOSED LOADS ON THE JAMBS FROM THIS DOOR ARE DESIGNED AS Vx AND Vy HEREIN. CONTRACTORS SHALL HAVE BUILDING ENGINEER VERIFY ADEQUACY OF BUILDING STRUCTURE TO RESIST SUPERIMPOSED LOADS Vx, Vy AND BRACKET LOADS SHOWN.
- ALL WELDING SHALL BE PERFORMED BY QUALIFIED WELDERS IN ACCORDANCE WITH A.W.S. SPECIFICATIONS, LATEST EDITION. ALL WELDING ELECTRODES SHALL CONFORM TO A.W.S. A5.1 GRADE E-70.
- DOORS SHALL BE PROVIDED WITH LOCK MECHANISMS AT THE OPTION OF THE OWNER.
- ALL BOLTS AND WASHERS SHALL BE GALVANIZED OR STAINLESS STEEL WITH A MINIMUM TENSILE STRENGTH OF 60 KSI.

- DESIGN BASED ON CERTIFIED TESTING LABORATORIES, INC., TEST REPORT NO. CTLA - 983W-2
- ANCHOR NOTES:  
A. EMBEDMENT LENGTH DOES NOT INCLUDE STUCCO FINISH.  
B. FOR HOLLOW MASONRY, FILL ALL CELLS @ ANCHOR WITH 2500 PSI GROUT.  
C. ANCHORS SHALL BE INSTALLED IN ACCORDANCE WITH MANUFACTURER'S SPECIFICATIONS.
- DOOR OPERATION TYPE TO BE PUSH-UP, HAND CHAIN OR ELECTRIC.

- GUIDE TO JAMB ATTACHMENT FASTENERS BEGIN 4" FROM FLOOR AND END 3-1/2" BELOW TOP OF WALL OPENING.
- TEST DOOR WALL OPENING SIZE: 8'-8" x 8'-0".

THESE CONFIDENTIAL DOCUMENTS SUBMITTED BY JANUS CONTAIN INFORMATION OF A PROPRIETARY NATURE AND MAY NOT BE REPRODUCED OR USED TO MANUFACTURE ANYTHING IN PART OR IN WHOLE FOR ANY PURPOSE OTHER THAN THAT WHICH IS NECESSARY FOR PREPARATION OF BIDS OF ENGINEERING WITHOUT THE EXPRESS PERMISSION OF JANUS WHICH MAY RECALL DOCUMENTS AT ANY TIME.

UNLESS OTHERWISE SPECIFIED DIMENSIONS ARE IN INCHES AND TOLERANCES ARE:

DECIMAL	FRACTIONS	ANGLES	HOLE DIAMETERS
.XX	±.03		UNDER .251 +.004 -.003
.XXX	±.005		.251 to .500 +.006 -.003
			OVER .500 +.008 -.003

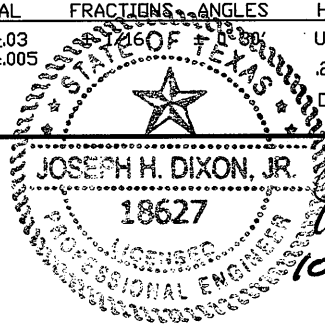

PART NUMBER:	
MATERIAL:	
APPLIED FINISH:	
UNIT OF MEASURE:	
APPROVALS	
DATE	
DRAWN BY	DATE
BECKY NELSON	5-30-07
CHECKED BY	DATE
DON MILLS	5-30-07
APPROVED BY	DATE
DON MILLS	5-30-07

**JANUS INTERNATIONAL CORPORATION**  
134 EAST LUKE ROAD TEMPLE, GA 30179-4435  
770-562-2850/Fax 770-562-2264  
© 2007 Janus International Corporation All Rights Reserved

CERTIFIED WIND LOAD RATED  
26 GA SERIES 1100 DOOR ASSEMBLY  
MAX. SIZE 8'-8" X 14'-0"

SIZE	DRAWING NUMBER	REV
<b>B</b>	T1012	<b>A</b>
SCALE	SHEET 2 OF 2	
NONE		

# TEXAS DEPARTMENT OF INSURANCE

Engineering Services / MC 103-3A 333 Guadalupe Street P.O. Box 149104 Austin, Texas 78714-9104  
Phone No. (512) 322-2212 Fax No. (512) 463-6693

---

## PRODUCT EVALUATION GDR-70

Effective May 1, 2011

*The following product has been evaluated for compliance with the wind loads specified in the International Residential Code (IRC) and the International Building code (IBC). This product shall be subject to reevaluation June 2015.*

*This product evaluation is not an endorsement of this product or a recommendation that this product be used. The Texas Department of Insurance has not authorized the use of any information contained in the product evaluation for advertising, or other commercial or promotional purpose.*

*This product evaluation is intended for use by those individuals who are following the design wind load criteria in Chapter 3 of the IRC and Section 1609 of the IBC. The design loads determined for the building or structure shall not exceed the design load rating specified for the products shown in the limitations section of this product evaluation. This product evaluation does not relieve a Texas licensed engineer of his responsibilities as outlined in the Texas Insurance Code, the Texas Administrative Code, and the Texas Engineering Practice Act.*

**Series 1100 Rolling Doors, Non-Impact Resistant**, as manufactured by:

**Janus International Corporation**  
**134 Janus International Blvd.**  
**Temple, Georgia 30179-4435**  
**(866) 562-2580**  
[www.janusintl.com](http://www.janusintl.com)

will be accepted for use in designated catastrophe areas along the Texas Gulf Coast when installed in accordance with this product evaluation and the approved drawings that are referenced in this evaluation report.

## PRODUCT DESCRIPTION

This evaluation report is for the following rolling doors:

**System 1: Doors through 8'-8" wide opening per Janus drawing T1012**  
**System 2: Doors through 10'-0" wide opening per Janus drawing T1013**

**General:** Janus Rolling Doors are made up of lock seamed together corrugated steel panels that span between the guides located on each side of an opening. The panels are constructed of 26 gauge material. The dimensions of the formed panels are 5/8" deep, 3 1/4" corrugation pitch, and 20" panel height. The panels are manufactured from ASTM A 653 GR 80 zinc coated steel and are pre-painted with a full coat of primer and baked siliconized polyester finish coat. Windlocks are attached to both ends of every other corrugation. Guides are a roll formed steel shape. Bottom bar is single roll formed steel angle construction. Sheets 1 and 2 of the approved drawings show the details of the door construction, guides, various components, and specific door requirements based on curtain type, opening widths, and design pressure requirements.

## LIMITATIONS

**Design Drawings:** The rolling doors shall be installed in accordance with Janus International Corporation drawings T1012 and T1013, sheets 1 and 2 of 2, dated June 17, 2009, signed and sealed by Joseph H. Dixon, P.E. on October 2, 2010. The stated drawings will be referred to as approved drawings in this report. A copy of the approved drawings shall be available at the job site.

**Wall Construction:** The rolling doors may be mounted to the following types of wall framing:

- Cast-in-place concrete (minimum 3,000 psi)
- Grout-filled masonry CMU (minimum 2,500 psi grout)
- Steel, minimum  $\frac{3}{16}$ " thick, A36

**Maximum Opening Width:** 10'-0"

**Maximum Opening Height:** 14'-0"

**Glazing:** Not permitted.

**Allowable Design Pressure Rating:**

Model	Maximum Wall Opening Width	Maximum Wall Opening Height	Drawing Number	Allowable Design Pressure (psf)
1100	8'-8"	14'-0"	T1012	+24.4, -27.0
1100	10'-0"	14'-0"	T1013	+19.4, -22.7

**Product Identification:** A label will be affixed to the rolling door. The label shall include the name, series, or model number of the door; the name of the door manufacturer; the design pressure rating for the door; and compliance with either ASTM E 330 or ANSI/DASMA 108.

**Impact Resistance:** These door assemblies do not satisfy the Texas Department of Insurance's criteria for protection from windborne debris. These door assemblies will need to be protected with an impact protective system when installed in areas where windborne debris protection is required. The assemblies may be installed at any height on the structure as long as the design pressure rating for the assemblies is not exceeded.

**Acceptance of Smaller Assemblies:** Door assemblies with dimensions equal to or smaller than those specified above are acceptable within the limitations specified in this report.

## INSTALLATION INSTRUCTIONS

**General Installation Requirements:** The rolling doors shall be installed in accordance with the manufacturer's installation instructions, the approved drawings, and this product evaluation report.

**Anchorage:** The rolling doors shall be anchored to the structure in accordance with the approved drawings. Anchorage of rolling doors to concrete, grout-filled CMU or steel shall follow the mounting details on the approved drawings and the fasteners specified in the mounting details. Minimum edge distances and minimum embedment depths for all fasteners that penetrate into the structure shall be as specified on the design drawings.

**Note:** The manufacturer's installation instructions and as build drawings shall be available on the job site during installation. All fasteners shall be corrosion resistant as specified in the International Residential Code (IRC) and the International Building Code (IBC).