

- NOTES:**
- OPERATION TYPE MAY BE PUSH-UP, HAND CHAIN OR ELECTRIC.
 - FOR CRITICAL FITS DUE TO REDUCED AVAILABLE HEADROOM OR SIDEROOM CLEARANCES, CONSULT FACTORY.
 - CLEARANCES SHOWN ARE MAXIMUMS. LESSER CLEARANCES MAY BE POSSIBLE.
 - UNLESS OTHERWISE NOTED, DOORS SHALL BE PROVIDED WITH SLIDE LOCKS AT EACH END OF BOTTOM BAR, ENGAGING GUIDES IN THE LOCKED POSITION.
 - ALL OPENING PREPARATION, ELECTRICAL POWER AND FIELD PAINTING SHALL BE PROVIDED BY OTHERS.
 - SERIES 190I IS AN INSULATED SERIES 190.
 - CURTAIN FINISH SHALL BE SILICONE POLYESTER PRE-PAINT OVER GALVANIZED GRADE 80 STEEL.
 - GUIDES, BRACKETS, BOTTOM BAR ANGLE AND HEAD STOPS ARE ZINC COATED.
 - MAXIMUM OPENING SIZE: 12'-0" X 14'-0".

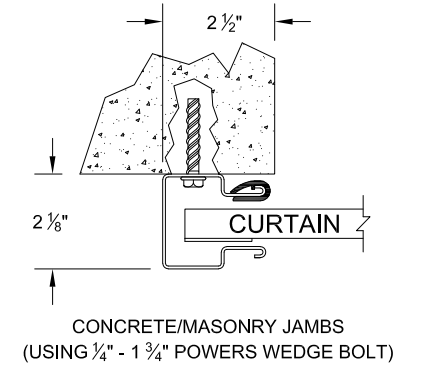
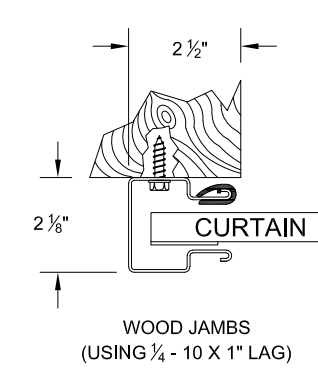
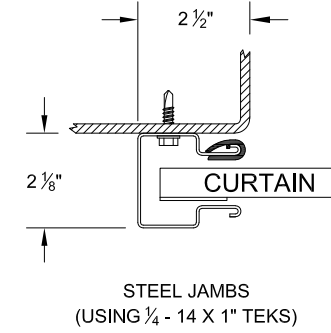
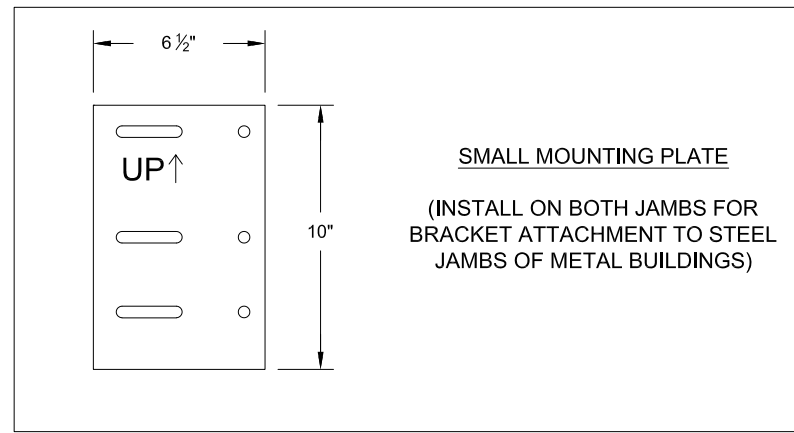

16 GA GUIDE MOUNTING DETAIL

BRACKET ATTACHMENT
 CONCRETE/MASONRY: POWERS WEDGE-BOLT, 3/8" X 1 3/4" LONG
 WOOD: LAG SCREW, 3/8" - 7 X 3" LONG
 STEEL: HEX BOLT, GR.5, 3/8" - 16 X 1 1/4" LONG

(*) FOR PUSH-UP OPERATION.....4 1/2"
 FOR HAND CHAIN OPERATION.....5 1/2"
 FOR ELECTRIC OPERATION.....6"
 FOR OUTSIDE OF CHAIN DRIVE.....7"
 NOTE: RIGHT SIDE DRIVE SHOWN

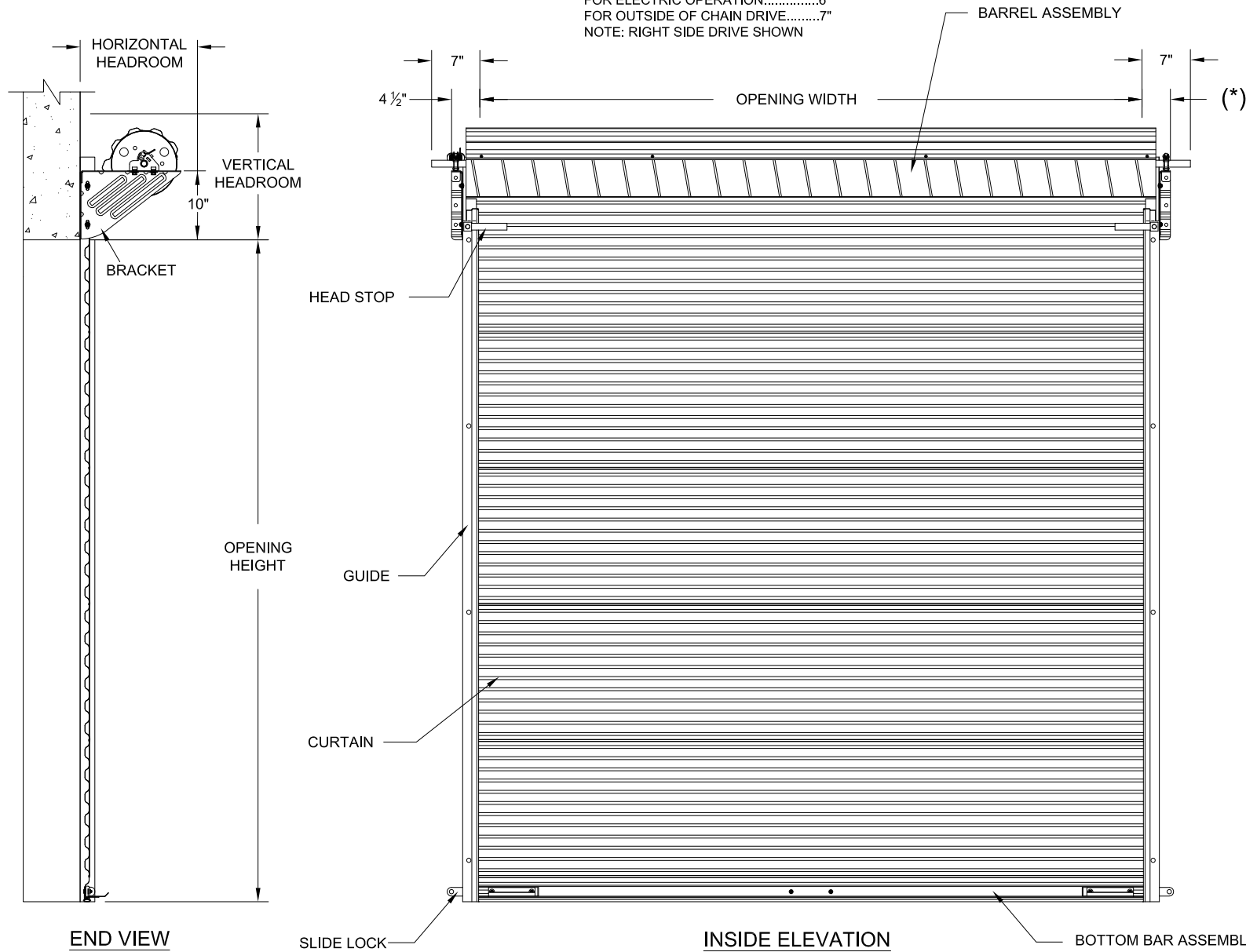

HEADROOM REQUIRED

OPENING HEIGHT	VERTICAL HEADROOM	HORIZONTAL HEADROOM
THRU 8'-0"	19"	19"
OVER 8'-0" THRU 10'-0"	20"	20"
OVER 10'-0" THRU 14'-0"	20 1/2"	20"

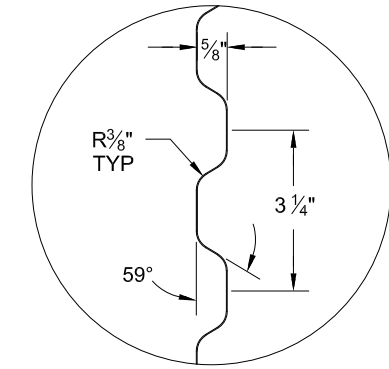

DETAIL A

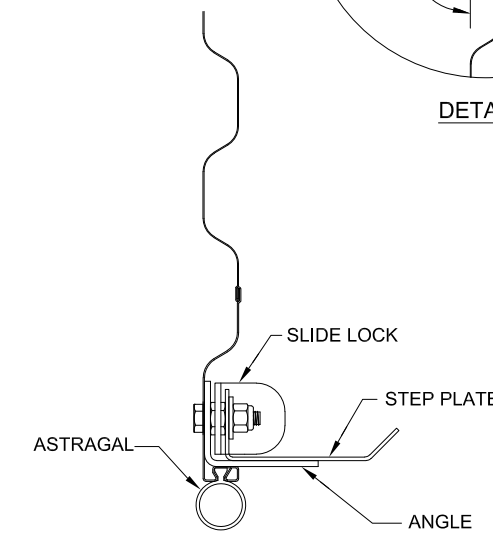

BOTTOM BAR ASSEMBLY

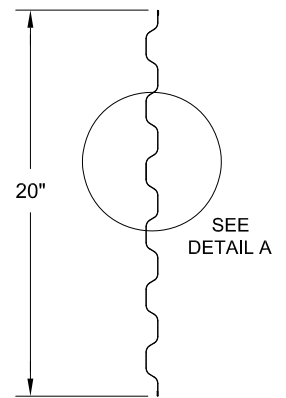

26 GA CURTAIN PANEL DETAIL

DRAWING NUMBER: 814006-0001

DATE: 07/18/2023

COMMERCIAL DOOR SERIES: 190/190I

CUSTOMER NUMBER:		DATE:	
CUSTOMER NAME:		CONTACT:	
PROJECT NAME:			
PROJECT LOCATION:			
PLANT:		SALESPERSON:	
DRAWN BY:		DATE:	
DRAWING NUMBER:		SHT:	OF:

FACTORY ORDER NUMBER	DOOR SERIES		QTY	OPENING SIZE		JAMB TYPE			OUTSIDE CURTAIN COLOR	OPERATION			OPERATION HAND	WEATHERSTRIP			ADDED OPTIONS
	190	190I		WIDTH	HEIGHT	STEEL	CONC./MAS	WOOD		PUSH UP	REDUCED CHAIN	ELECTRIC		TOP	HEADER	SIDE	