

BRACKET ATTACHMENT
 CONCRETE/FILLED BLOCK: POWERS WEDGE-BOLT, 3/8 X 1 3/4" LONG
 STEEL: HEX BOLT, GR 5, 3/8-16 X 1 1/4" LONG OR 3/8-16 X 1" HWH
 TYPE 23 THREAD-CUTTING SCREW

(*) FOR PUSH-UP OPERATION: 3 7/8"
 FOR HAND CHAIN OPERATION: 4 5/8"
 FOR ELECTRIC OPERATION: 5 3/8"
 FOR OUTSIDE OF CHAIN DRIVE: 6 1/8"
 NOTE: RIGHT SIDE DRIVE SHOWN

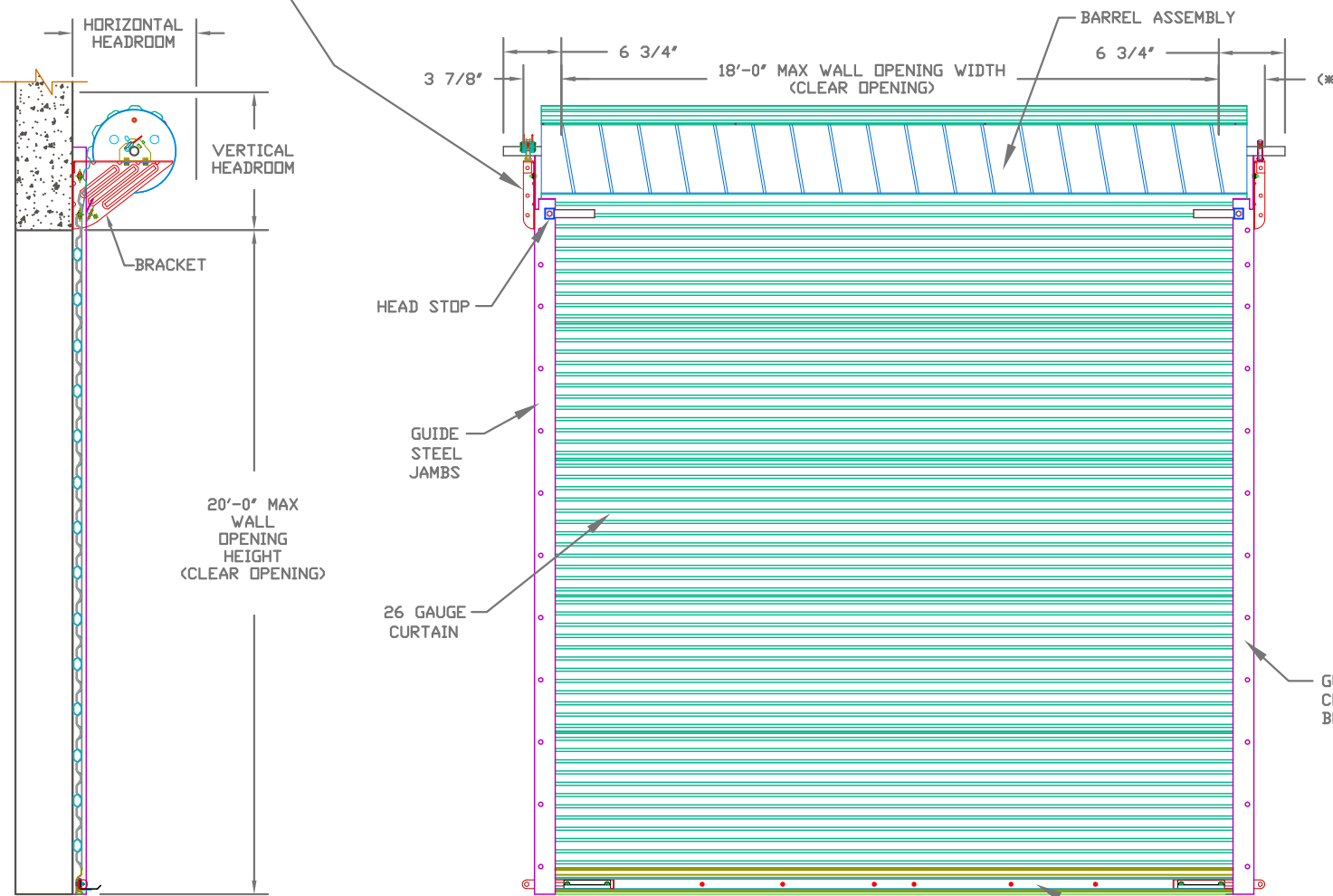

HEADROOM REQUIRED		
OPENING HEIGHT	VERTICAL HEADROOM	HORIZONTAL HEADROOM
THRU 8'-0"	17"	19"
OVER 8'-0" THRU 10'-0"	19"	21"
OVER 10'-0" THRU 14'-0"	20"	22"
OVER 14'-0" THRU 16'-0"	21"	23"
OVER 16'-0" THRU 18'-0"	22"	24"
OVER 18'-0" THRU 20'-0"	23"	25"

ALLOWABLE TRANSVERSE DESIGN WIND LOADS (PSF)			
MAX DOOR WIDTH	MAX DOOR HEIGHT	DESIGN LOAD POSITIVE (PSF)	DESIGN LOAD NEGATIVE (PSF)
6'-0"	20'-0"	72.9	79.2
7'-0"	20'-0"	72.9	79.2
8'-0"	20'-0"	72.9	79.2
9'-0"	20'-0"	56.4	61.7
10'-0"	20'-0"	51.6	56.8
11'-0"	20'-0"	42.6	47.1
12'-0"	20'-0"	36.0	40.0
13'-0"	20'-0"	31.0	34.5
14'-0"	20'-0"	27.0	30.2
15'-0"	20'-0"	23.9	26.8
16'-0"	20'-0"	21.3	23.9
17'-0"	20'-0"	19.2	21.6
18'-0"	20'-0"	17.4	19.6

REVISIONS			
REV	DESCRIPTION	DATE	APPROVAL
-	DRAWING RELEASE	2-21-11	DM

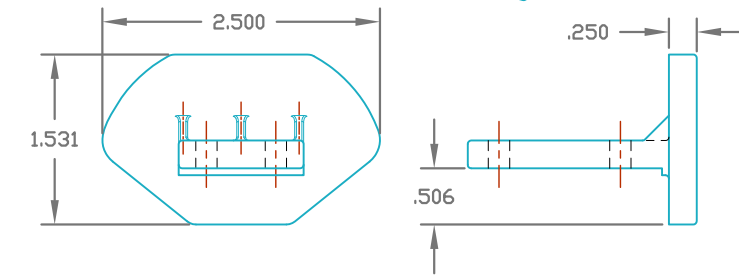
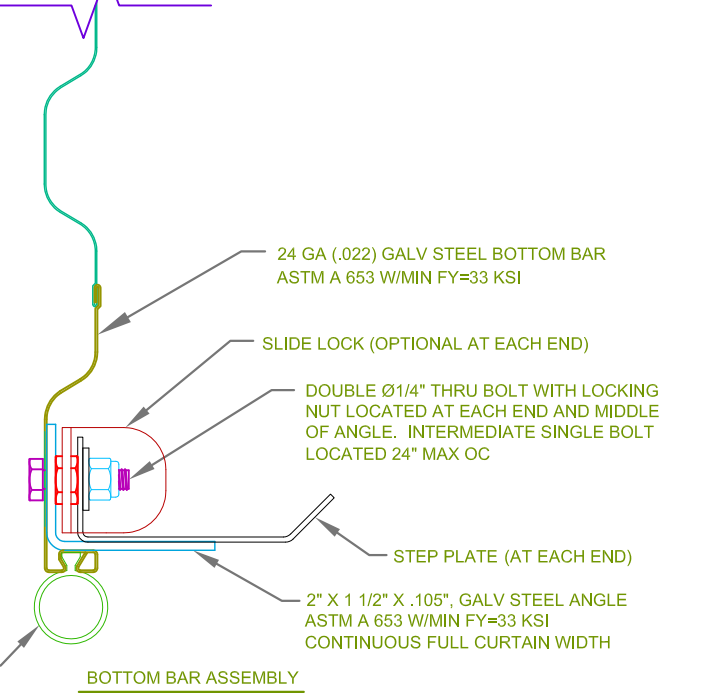
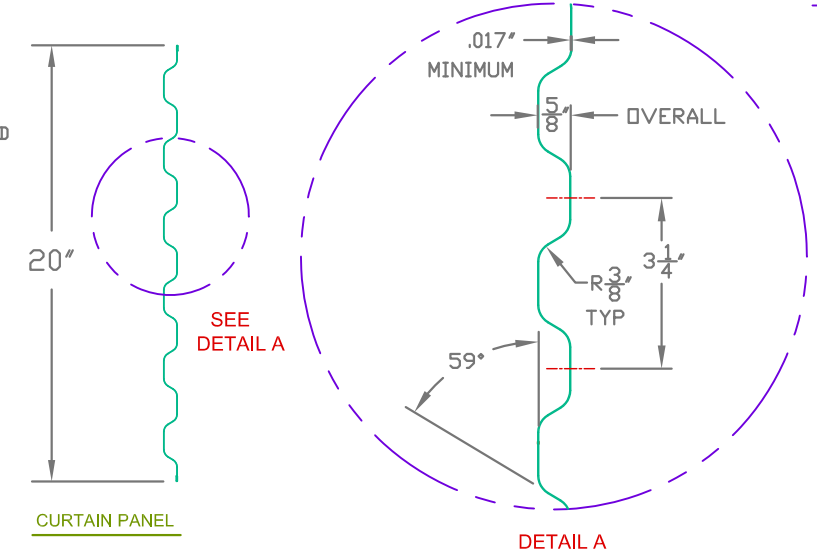
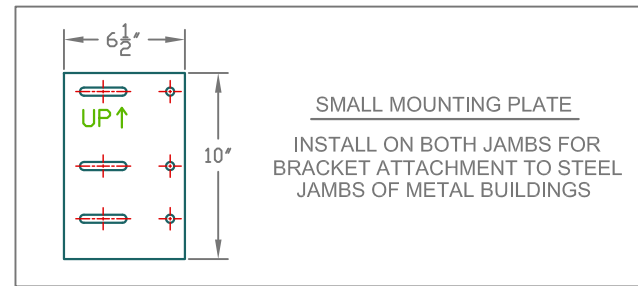
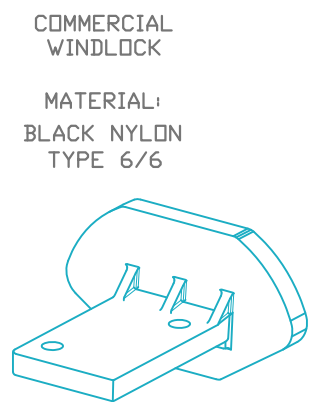
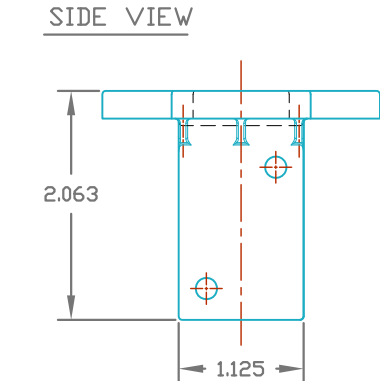

SEE SHEET 2 FOR NOTES

THESE CONFIDENTIAL DOCUMENTS SUBMITTED BY JANUS CONTAIN INFORMATION OF A PROPRIETARY NATURE AND MAY NOT BE REPRODUCED OR USED TO MANUFACTURE ANYTHING IN PART OR IN WHOLE FOR ANY PURPOSE OTHER THAN THAT WHICH IS NECESSARY FOR PREPARATION OF BIDS OF ENGINEERING WITHOUT THE EXPRESS PERMISSION OF JANUS WHICH MAY RECALL DOCUMENTS AT ANY TIME.

UNLESS OTHERWISE SPECIFIED DIMENSIONS ARE IN INCHES AND TOLERANCES ARE:

	DECIMAL	FRACTIONS	ANGLES	HOLE DIAMETERS
	.XX ±.03	± 1/16	± 0° 30'	UNDER .251 +.004 -.003
	.XXX ±.005			.251 to .500 +.006 -.003
				OVER .500 +.008 -.003

PART NUMBER:	NA
MATERIAL:	NA
APPLIED FINISH:	NA
UNIT OF MEASURE:	NA
APPROVALS:	DATE
DRAWN: BECKY NELSON	2-1-11
CHECKED: DON MILLS	2-21-11
APPROVED: DON MILLS	2-21-11

JANUS INTERNATIONAL CORPORATION
 134 JANUS INTERNATIONAL BLVD TEMPLE, GA 30179
 770-562-2850/Fax 770-562-2264
 © 2011 Janus International Corporation All Rights Reserved

CERTIFIED WIND LOAD RATED
26 GA SERIES 3652 DOOR ASSEMBLY
MAX SIZE 18'-0" X 20'-0"

SIZE: B	DRAWING NUMBER: T1014	REV: —
SCALE: NONE	SHEET: 1 OF: 2	

REVISIONS			
REV	DESCRIPTION	DATE	APPROVAL
-	DRAWING RELEASE	2-21-11	DM

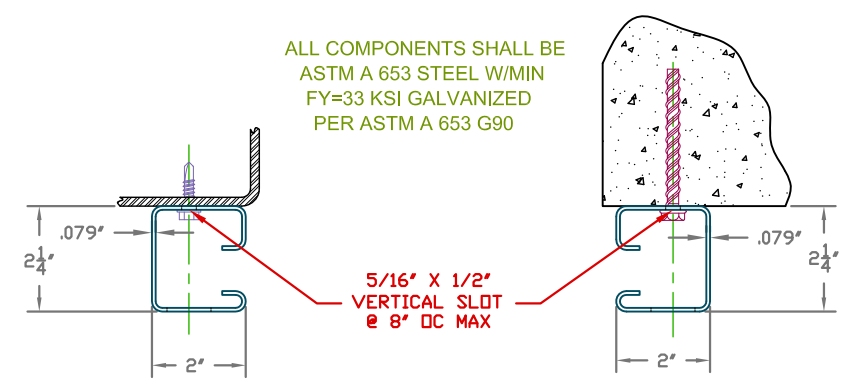

GUIDE MOUNTED TO STEEL JAMBS USING 1/4-14 X 1\"/>

GUIDE MOUNTED TO CONCRETE/FILLED BLOCK JAMBS USING 1/4\"/>

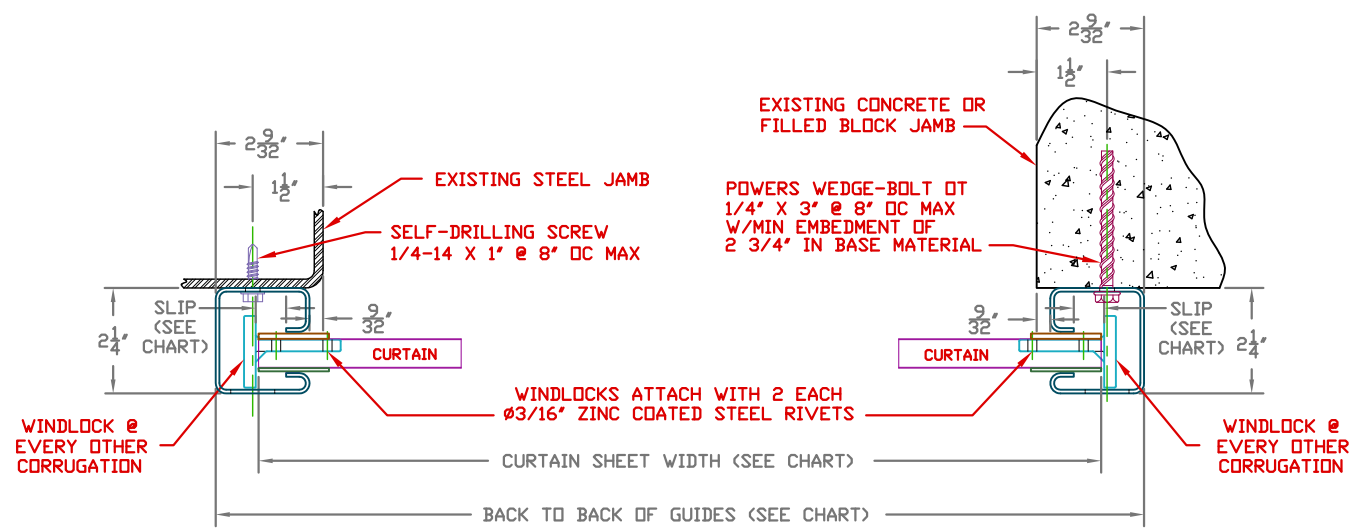

STEEL JAMBS LH GUIDE MOUNT SHOWN

CONCRETE/FILLED BLOCK JAMBS RH GUIDE MOUNT SHOWN

OPENING WIDTH	SLIP	CURTAIN SHEET WIDTH	BACK TO BACK OF GUIDES
≤7'-0"	3/8"	OPENING WIDTH + 2 3/16"	CURTAIN SHEET WIDTH + 2 3/8"
>7'-0" ≤9'-0"	1/2"	OPENING WIDTH + 2 7/16"	CURTAIN SHEET WIDTH + 2 1/8"
>9'-0" ≤18'-0"	21/32"	OPENING WIDTH + 2 3/4"	CURTAIN SHEET WIDTH + 1 13/16"

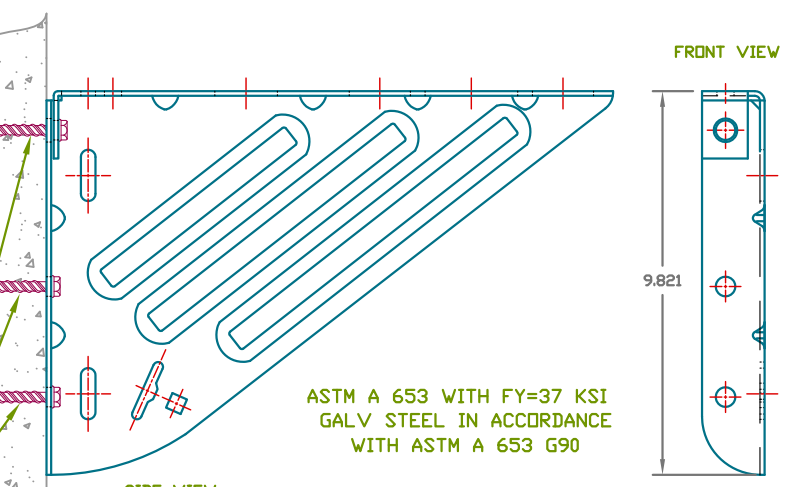
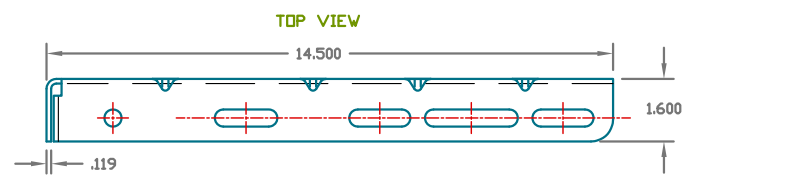

LH DOOR MOUNTING BRACKET DETAIL

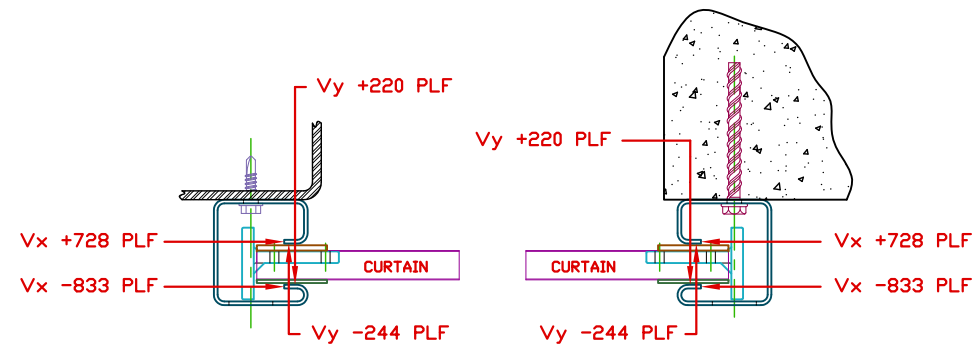

STEEL JAMBS LH GUIDE MOUNT SHOWN

CONCRETE/FILLED BLOCK JAMBS RH GUIDE MOUNT SHOWN

SUPERIMPOSED LOAD DIAGRAM

GENERAL NOTES

- THIS ROLL-UP DOOR SYSTEM IS DESIGNED IN ACCORDANCE WITH THE FLORIDA BUILDING CODE AND THE INTERNATIONAL BUILDING CODE. THE REQUIRED DESIGN WIND PRESSURES FOR A DOOR IN ANY PARTICULAR BUILDING SHALL BE DETERMINED IN ACCORDANCE WITH SECTION 1609 OF THE FBC. IN CODE JURISDICTIONS OUTSIDE OF FLORIDA, REQUIRED DESIGN WIND PRESSURES MAY BE DETERMINED IN ACCORDANCE WITH SECTION 1609 OF THE IBC OR WITH THE LOCAL BUILDING CODE IN EFFECT FOR THE SPECIFIC LOCATION.
- THIS ROLL-UP DOOR HAS BEEN SUCCESSFULLY TESTED ACCORDING TO THE UNIFORM STATIC AIR PRESSURE TEST PER ASTM E 330 AND ANSI/DASMA 108 TO SAFELY RESIST A POSITIVE AND NEGATIVE WIND LOAD AS NOTED BELOW. A TEST LOAD OF 1.5 X DESIGN LOAD HAS BEEN USED.

DESIGN LOAD = +36.0 PSF
-40.0 PSF
- WIND LOADS FOR BUILDING OPENINGS SHALL BE DETERMINED BY A PROFESSIONAL ENGINEER USING APPROPRIATE WIND SPEED AND DESIGN CRITERIA. THIS DOOR MAY BE USED WHERE THE DESIGN LOAD MEETS OR EXCEEDS THE DESIGN LOAD FOR THE BUILDING OPENING.
- SUPERIMPOSED LOADS ON THE JAMBS FROM THIS DOOR ARE DESIGNED AS Vx AND Vy HEREIN. CONTRACTORS SHALL HAVE BUILDING ENGINEER VERIFY ADEQUACY OF BUILDING STRUCTURE TO RESIST SUPERIMPOSED LOADS Vx, Vy.
- ALL WELDING SHALL BE PERFORMED BY QUALIFIED WELDERS IN ACCORDANCE WITH AWS SPECIFICATIONS, LATEST EDITION. ALL WELDING ELECTRODES SHALL CONFORM TO AWS A5.1 GRADE E-70.
- DOORS MAY BE PROVIDED WITH LOCK MECHANISMS AT THE OPTION OF THE OWNER.
- ALL BOLTS AND WASHERS SHALL BE GALVANIZED OR STAINLESS STEEL WITH A MINIMUM TENSILE STRENGTH OF 60 KSI.
- DESIGN BASED ON CERTIFIED TESTING LABORATORIES, INC., TEST REPORT NO. CTLA 2058W DATED FEBRUARY 17, 2011. (STATIC PRESSURE)
- ANCHOR NOTES:
A. EMBEDMENT LENGTH DOES NOT INCLUDE STUCCO FINISH.
B. FOR HOLLOW BLOCK, FILL ALL CELLS @ ANCHOR WITH 2500 PSI GROUT.
C. ANCHORS SHALL BE INSTALLED IN ACCORDANCE WITH MANUFACTURER'S SPECIFICATIONS.
- DOOR OPERATION TYPE TO BE PUSH-UP, HAND CHAIN, OR ELECTRIC.
- GUIDE TO JAMB ATTACHMENT FASTENERS IN WALL OPENING AREA BEGIN 4" FROM FLOOR AND END 4" BELOW THE TOP OF WALL OPENING.
- TEST DOOR WALL OPENING SIZE: 12'-0" X 8'-0".

THESE CONFIDENTIAL DOCUMENTS SUBMITTED BY JANUS CONTAIN INFORMATION OF A PROPRIETARY NATURE AND MAY NOT BE REPRODUCED OR USED TO MANUFACTURE ANYTHING IN PART OR IN WHOLE FOR ANY PURPOSE OTHER THAN THAT WHICH IS NECESSARY FOR PREPARATION OF BIDS OF ENGINEERING WITHOUT THE EXPRESS PERMISSION OF JANUS WHICH MAY RECALL DOCUMENTS AT ANY TIME.		PART NUMBER: NA		JANUS INTERNATIONAL CORPORATION 134 JANUS INTERNATIONAL BLVD TEMPLE, GA 30179 770-562-2850/Fax 770-562-2264 © 2011 Janus International Corporation All Rights Reserved	
UNLESS OTHERWISE SPECIFIED DIMENSIONS ARE IN INCHES AND TOLERANCES ARE:		MATERIAL: NA			
DECIMAL FRACTIONS ANGLES HOLE DIAMETERS		APPLIED FINISH: NA			
.XX ±.03 ± 1/16 ± 0° 30'		UNIT OF MEASURE: NA			
.XXX ±.005		APPROVALS DATE		CERTIFIED WIND LOAD RATED 26 GA SERIES 3652 DOOR ASSEMBLY MAX SIZE 18'-0" X 20'-0"	
		DRAWN: BECKY NELSON 2-1-11			
		CHECKED: DON MILLS 2-21-11			
		APPROVED: DON MILLS 2-21-11			
		SIZE: B	DRAWING NUMBER: T1014		REV: —
		SCALE: NONE	SHEET: 2 OF 2		