

ASTM A653 GR 80 ZINC COATED STEEL
 PRE-PAINTED WITH FULL COAT OF PRIMER AND
 BAKED SILICONIZED POLYESTER FINISH COAT
 26 GA CURTAIN DETAIL

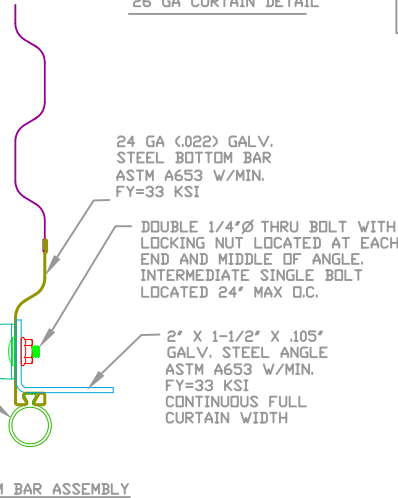

REVISIONS			
REV	DESCRIPTION	DATE	APPROVAL
1	DRAWING RELEASE	11-14-02	DM
A	NOTE REVISIONS	4-16-04	DM

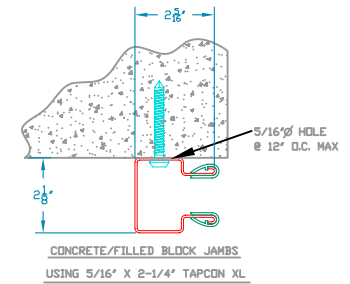

ALL COMPONENTS SHALL BE
 ASTM A653 STEEL W/MIN
 FY=33 KSI GALVANIZED
 PER ASTM A653 5-90

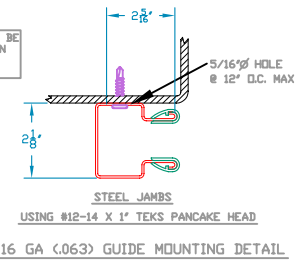

OPENING HEIGHT	VERTICAL HEADROOM	HORIZONTAL HEADROOM
THRU 7'-4"	15-1/2"	17-1/2"
OVER 7'-4" THRU 8'-8"	16"	18"
OVER 8'-8" THRU 10'-0"	17"	18-1/4"

HEADROOM REQUIRED

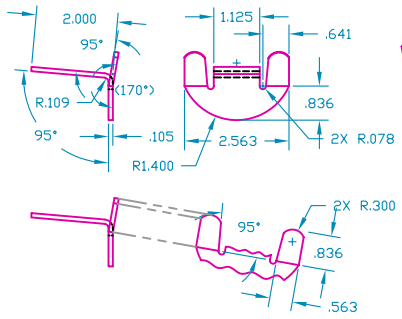

WINDLOCK
 GALV. STEEL,
 ASTM A653
 WITH MIN.
 FY=33KSI

THESE CONFIDENTIAL DOCUMENTS SUBMITTED BY JANUS CONTAIN INFORMATION OF A PROPRIETARY NATURE AND MAY NOT BE REPRODUCED OR USED TO MANUFACTURE ANYTHING IN PART OR IN WHOLE FOR ANY PURPOSE OTHER THAN THAT WHICH IS NECESSARY FOR PREPARATION OF BIDS OF ENGINEERING WITHOUT THE EXPRESS PERMISSION OF JANUS WHICH MAY RECALL DOCUMENTS AT ANY TIME.

UNLESS OTHERWISE SPECIFIED DIMENSIONS ARE IN INCHES AND TOLERANCES ARE:

DECIMAL	FRACTIONS	ANGLES	HOLE DIAMETERS
.XX ±.03	± 1/16	± 0° 30'	UNDER .251 +.004 -.003
.XXX ±.005			.251 to .500 +.006 -.003
			OVER .500 +.008 -.003

PART NUMBER:	
MATERIAL:	
APPLIED FINISH:	
UNIT OF MEASURE:	
APPROVALS	DATE
DRAWN: BECKY NELSON	11-14-02
CHECKED: DON MILLS	11-14-02
APPROVED: DON MILLS	11-14-02

JANUS INTERNATIONAL CORPORATION
 134 EAST LUKE ROAD TEMPLE, GA 30179-4435
 770-562-2850/Fax 770-562-2264
 © 2005 Janus International Corporation All Rights Reserved

CERTIFIED WIND LOAD RATED
26 GA SERIES 750 DOOR ASSEMBLY
 MAX. SIZE 8'-8" X 12'-0"

SIZE: **B** DRAWING NUMBER: **T1002** REV: **A**

SCALE: NONE SHEET: 1 OF 2

REVISIONS			
REV	DESCRIPTION	DATE	APPROVAL
—	DRAWING RELEASE	11-14-02	DM
A	NOTE REVISIONS	4-16-04	DM

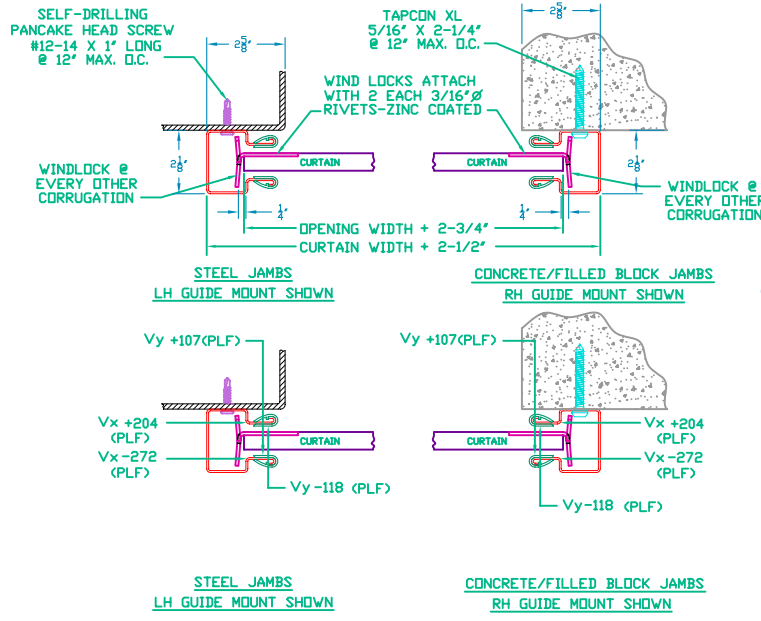

SUPERIMPOSED LOAD DIAGRAM

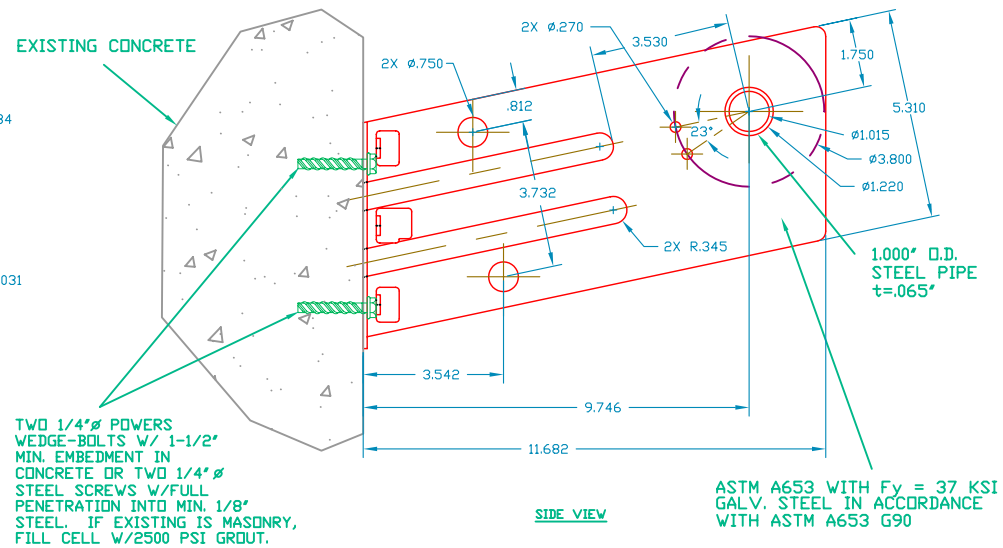
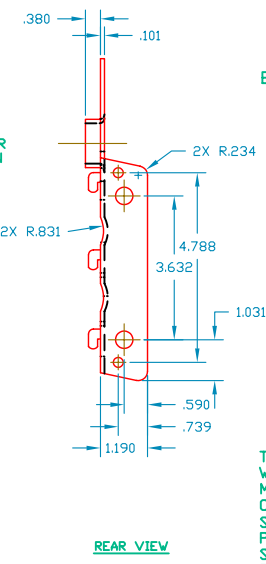

DOOR MOUNTING BRACKET DETAIL

GENERAL NOTES

- THIS ROLL-UP DOOR SYSTEM IS DESIGNED IN ACCORDANCE WITH THE STANDARD BUILDING CODE 1999 EDITION, ASCE 7-98, FLORIDA BUILDING CODE 2004 AND INTERNATIONAL BUILDING CODE 2000.
- THIS ROLL-UP DOOR HAS BEEN TESTED IN ACCORDANCE WITH ASTM E-330 TO SAFELY RESIST A POSITIVE OR NEGATIVE WIND LOAD AS NOTED BELOW. A TEST LOAD OF 1.5 X DESIGN LOAD HAS BEEN USED.
- WIND LOADS FOR BUILDING OPENINGS SHALL BE DETERMINED BY A PROFESSIONAL ENGINEER USING APPROPRIATE WIND SPEED AND DESIGN CRITERIA. THIS DOOR MAY BE USED WHERE THE DESIGN LOAD MEETS OR EXCEEDS THE DESIGN LOAD FOR THE BUILDING OPENING.
- SUPERIMPOSED LOADS ON THE JAMBS FROM THIS DOOR ARE DESIGNED AS Vx AND Vy HEREIN. CONTRACTORS SHALL HAVE BUILDING ENGINEER VERIFY ADEQUACY OF BUILDING STRUCTURE TO RESIST SUPERIMPOSED LOADS Vx, Vy AND BRACKET LOADS SHOWN.
- ALL WELDING SHALL BE PERFORMED BY QUALIFIED WELDERS IN ACCORDANCE WITH A.W.S. SPECIFICATIONS, LATEST EDITION. ALL WELDING ELECTRODES SHALL CONFORM TO A.W.S. A5.1 GRADE E-70.
- DOORS SHALL BE PROVIDED WITH LOCK MECHANISMS AT THE OPTION OF THE OWNER.
- ALL BOLTS AND WASHERS SHALL BE GALVANIZED OR STAINLESS STEEL WITH A MINIMUM TENSILE STRENGTH OF 60 KSI.

DESIGN LOAD = +24.4 PSF
-27.0

- DESIGN BASED ON CERTIFIED TESTING LABORATORIES, INC., TEST REPORT NO. CTLA - 983W-2
- ANCHOR NOTES:
 - EMBEDMENT LENGTH DOES NOT INCLUDE STUCCO FINISH.
 - FOR HOLLOW MASONRY, FILL ALL CELLS @ ANCHOR WITH 2500 PSI GROUT.
 - ANCHORS SHALL BE INSTALLED IN ACCORDANCE WITH MANUFACTURER'S SPECIFICATIONS.
- DOOR OPERATION TYPE TO BE PUSH-UP.

- GUIDE TO JAMB ATTACHMENT FASTENERS BEGIN 4" FROM FLOOR AND END 3-1/2" BELOW TOP OF WALL OPENING.
- TEST DOOR WALL OPENING SIZE: 8'-8" x 8'-0".

THESE CONFIDENTIAL DOCUMENTS SUBMITTED BY JANUS CONTAIN INFORMATION OF A PROPRIETARY NATURE AND MAY NOT BE REPRODUCED OR USED TO MANUFACTURE ANYTHING IN PART OR IN WHOLE FOR ANY PURPOSE OTHER THAN THAT WHICH IS NECESSARY FOR PREPARATION OF BIDS OF ENGINEERING WITHOUT THE EXPRESS PERMISSION OF JANUS WHICH MAY RECALL DOCUMENTS AT ANY TIME.

UNLESS OTHERWISE SPECIFIED DIMENSIONS ARE IN INCHES AND TOLERANCES ARE:

DECIMAL	FRACTIONS	ANGLES	HOLE DIAMETERS
.XX ±.03	± 1/16	± 0° 30'	UNDER .251 +.004 -.003
.XXX ±.005			.251 to .500 +.006 -.003
			OVER .500 +.008 -.003

PART NUMBER:		JANUS INTERNATIONAL CORPORATION	
MATERIAL:		134 EAST LUKE ROAD TEMPLE, GA 30179-4435	
APPLIED FINISH:		770-562-2850/Fax 770-562-2264	
UNIT OF MEASURE:		© 2005 Janus International Corporation All Rights Reserved	
APPROVALS:		CERTIFIED WIND LOAD RATED	
DATE:		26 GA SERIES 750 DOOR ASSEMBLY	
DRAWN:	DATE:	MAX. SIZE 8'-8" X 12'-0"	
BECKY NELSON	11-14-02	SIZE:	DRAWING NUMBER:
CHECKED:	DATE:	B	T1002
DON MILLS	11-14-02	SCALE:	NONE
APPROVED:	DATE:	SHEET:	OF:
DON MILLS	11-14-02	2	2